

GN Series Solid State Relays

- ▶ Current ratings from 10 to 125 amps
- ▶ Output voltage from 24 to 660 Vac
- ▶ Back to back SCR's for severe inductive loads
- ▶ Direct bond copper substrate
- ▶ Improved power lead frame design
- ▶ LED input status indicator
- ▶ Transient protection built in
- ▶ 4000 Vac optical isolation
- ▶ Available with IP20 "touch-safe" cover
- ▶ UL E79183, CSA LR 38595, TUV Approved, CE Compliant



Output Specifications

Voltage range (Vrms)	24 - 280Vac		48 - 660Vac			
Peak Voltage (Vpk , t = 1 min.)	600		1200			
Off-state leakage (@ max. line voltage & Ta = 25°C)	0.1mArms		0.25mArms			
Output Current (Mounted on proper heat sink, see deratings)	10	25	50	75	100	125
Minimum Current (mArms)	50	50	100	100	100	100
1 cycle surge current (50 Hz)	150	275	710	1050	1120	1600
1 cycle surge current (60 Hz)	175	300	750	1100	1200	1700
1 second surge current (Apk, Ta = 25°C) 50/60 Hz	50	85	150	225	300	375
Forward voltage drop (Vpk @ Imax, Ta = 25°C)	1.35	1.35	1.35	1.3	1.3	1.3
I ² T (50Hz, ½ cycle)	110	380	2520	5500	6270	12800
I ² T (60Hz, ½ cycle)	120	370	2320	5000	6000	12050
Rjb (thermal res. Junction to baseplate, °C/W)	0.5	0.4	0.25	0.155	0.155	0.15
Static off-state dv/dt (Vµs, Ta = 25°C)	500	500	500	500	500	500
Minimum heat sink @ ambient (for max current = °C/W & Ta)	3.0 @ 70°C	1.5 @ 50°C	1.0 @ 40°C	0.7 @ 40°C	0.5 @ 40°C	0.4 @ 40°C

Input Specifications

Input voltage*	3-32Vdc	18-36Vac	90-280Vac***
Drop out voltage	1 Vdc	2 Vrms	10 Vrms
Max. input current	14mA	16mArms	10mArms
Min. input current (for on-state)	7mA		5mArms
Input Resistance	Current Regulated		
Turn-on time**	8.33ms	20ms	20ms
Turn-off time	8.33ms	30ms	30ms

* 4-32Vdc for 48-660Vac models

** Random SSR's turn on in less than 100µs

General Characteristics

Operating Temperature (°C)****	-20 to + 80
Storage Temperature (°C)	-40 to + 100
Input to output isolation	4000Vrms
Input/output to ground isolation	2500Vrms
Input to output capacitance	8pF (typical)
Operating Frequency	47 to 63 Hz
Housing Material	UL 94V0 (self extinguishing)

Safety and Noise Immunity Compliance

CE Compliant with the LVD 73/23/EEC

UL / cUL Recognized per UL 508 and CSA C22.2 no. 14-M91

TUV EN60950

IEC 1000-4-2: Electrostatic Discharge - Level 3

IEC 1000-4-3: Radiated Electromagnetic Noise - Level 3

IEC 1000-4-4: Electrically Fast Transients - Level 3

IEC 1000-4-5: Electrical Surges - Level 3

IEC 1000-4-6: Conducted Electromagnetic Noise - Level 3

CISPR 11 - Class A: Allowable Levels of Conducted and Radiated Noise for Industrial Environments

*** For ambient temperatures above 40°C the maximum control voltage must not exceed 250Vac

**** Increase minimum input voltage by 1 Vdc for operation from -20° to -40°C

Part Numbers

(Zero Crossing)

Rating	Output	Input	IP00	IP20
10 Amp	24-280Vac	90-280Vac	84 134 001	84 137 001
		3-32Vdc	84 134 000	84 137 000
	48-660Vac	90-280Vac	84 134 101	84 137 101
		4-32Vdc	84 134 100	84 137 100
25 Amp	24-280Vac	90-280Vac	84 134 011	84 137 011
		3-32Vdc	84 134 010	84 137 010
	48-660Vac	90-280Vac	84 134 111	84 137 111
		4-32Vdc	84 134 110	84 137 110
50 Amp	24-280Vac	90-280Vac	84 134 021	84 137 021
		3-32Vdc	84 134 020	84 137 020
	48-660Vac	90-280Vac	84 134 121	84 137 121
		4-32Vdc	84 134 120	84 137 120
75 Amp	24-280Vac	90-280Vac	84 134 031	84 137 031
		3-32Vdc	84 134 030	84 137 030
	48-660Vac	90-280Vac	84 134 131	84 137 131
		4-32Vdc	84 134 130	84 137 130
100 Amp	24-280Vac	90-280Vac	84 134 041	84 137 041
		3-32Vdc	84 134 040	84 137 040
	48-660Vac	90-280Vac	84 134 141	84 137 141
		4-32Vdc	84 134 140	84 137 140
125 Amp	24-280Vac	90-280Vac	84 134 081	84 137 081
		3-32Vdc	84 134 080	84 137 080
	48-660Vac	90-280Vac	84 134 181	84 137 181
		4-32Vdc	84 134 180	84 137 180

Random SSR's

Rating	Output	Input	IP00	IP20
10 Amp	24-280Vac	3-32Vdc	84 134 200	84 137 200
	48-660Vac	4-32Vdc	84 134 300	84 137 300
25 Amp	24-280Vac	3-32Vdc	84 134 210	84 137 210
	48-660Vac	4-32Vdc	84 134 310	84 137 310
50 Amp	24-280Vac	3-32Vdc	84 134 220	84 137 220
	48-660Vac	4-32Vdc	84 134 320	84 137 320
75 Amp	24-280Vac	3-32Vdc	84 134 230	84 137 230
	48-660Vac	4-32Vdc	84 134 330	84 137 330
100 Amp	24-280Vac	3-32Vdc	84 134 240	84 137 240
	48-660Vac	4-32Vdc	84 134 340	84 137 340
125 Amp	24-280Vac	3-32Vdc	84 134 280	84 137 280
	48-660Vac	4-32Vdc	84 134 380	84 137 380

For 18-36Vac control replace the last digit in the part number with a 2. Example: 84134012

DIMENSIONS IN INCHES

IP00

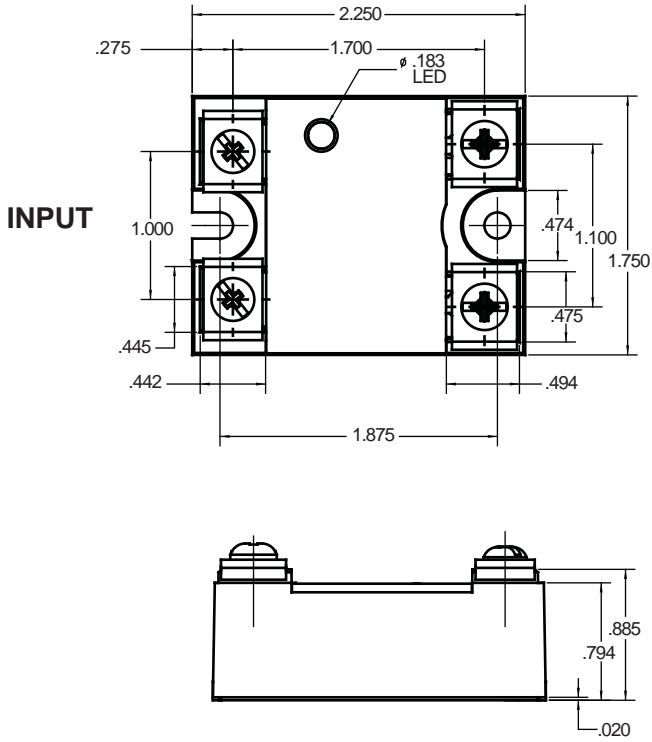

IP20

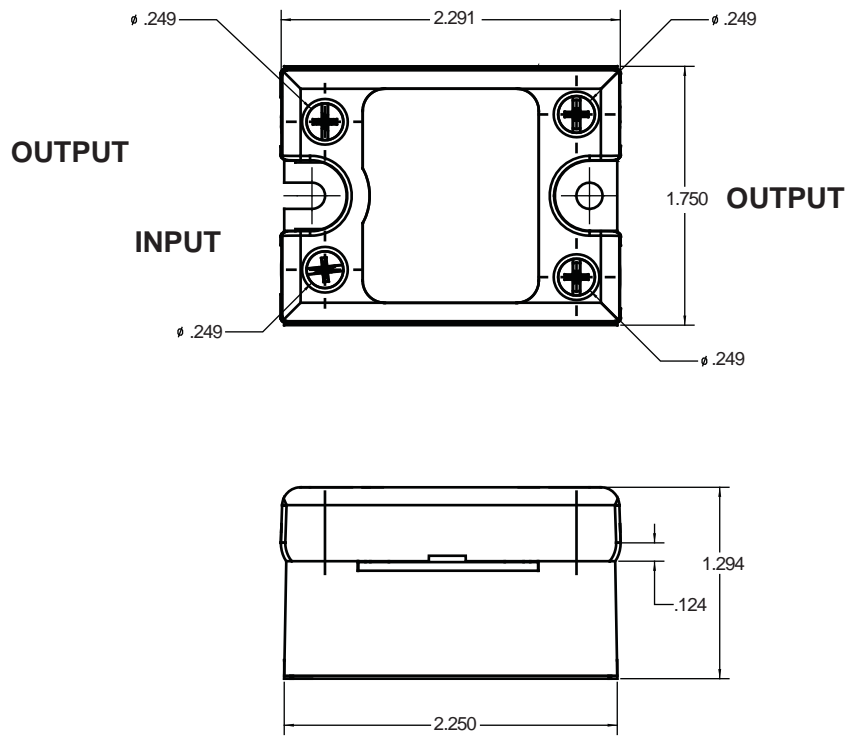

DERATING CURVES

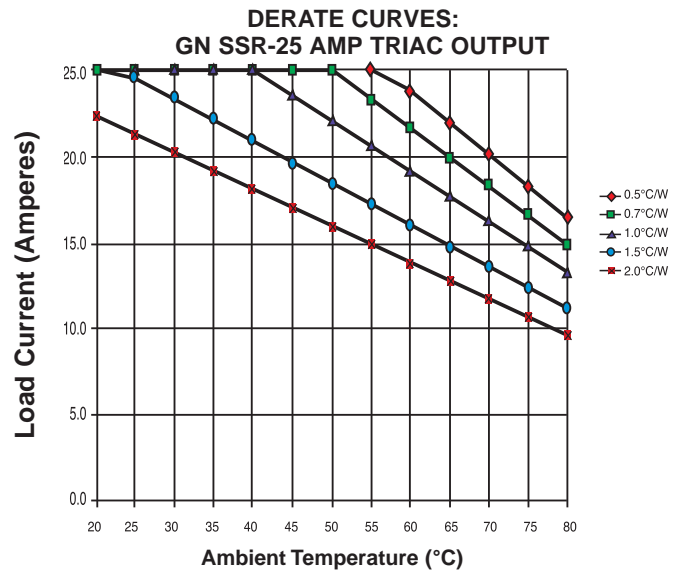
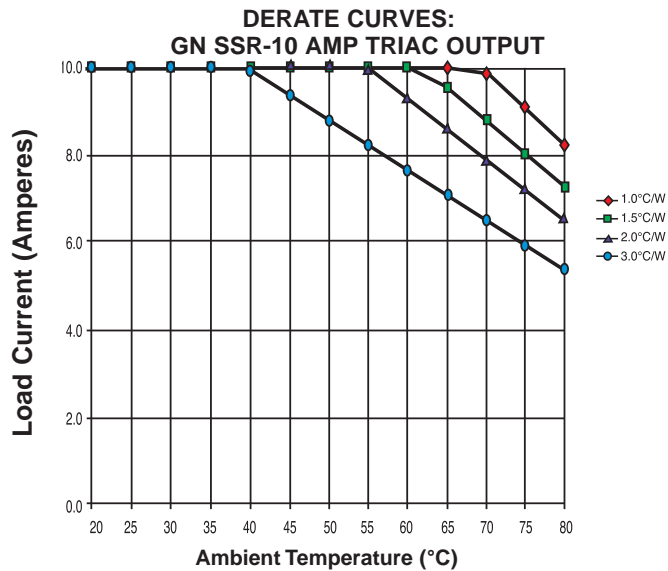

Products and specifications subject to change without notice.

Order/Technical Support – Tel: (877) 502-5500 / FAX: (619) 710-8540 / www.crouzet-usa.com

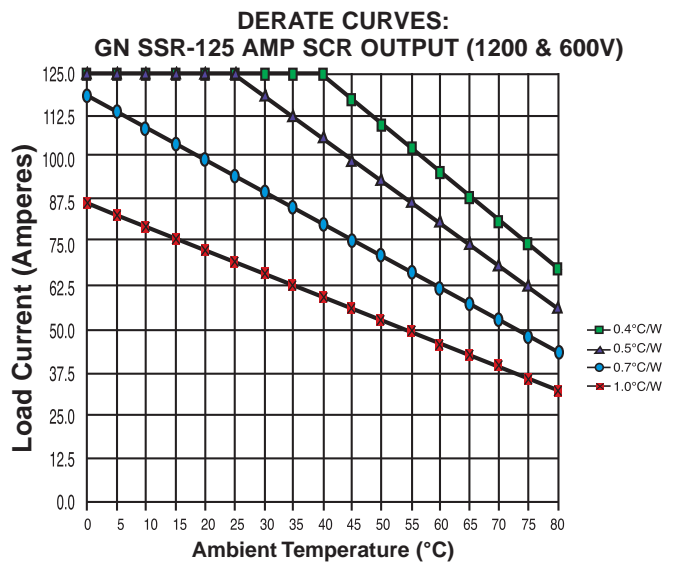
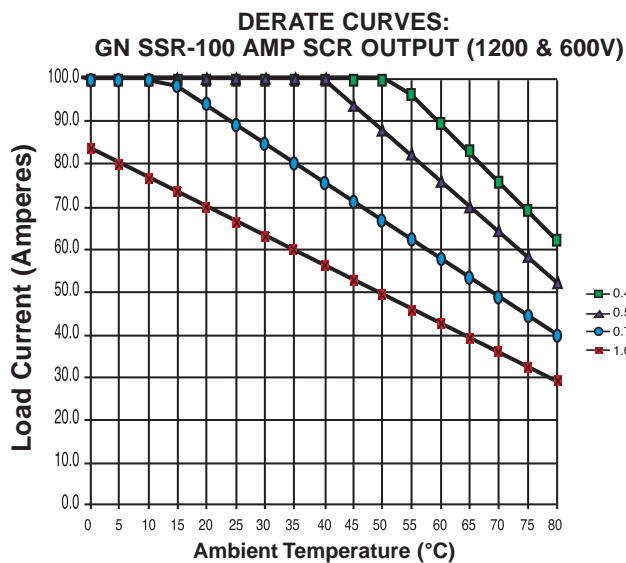
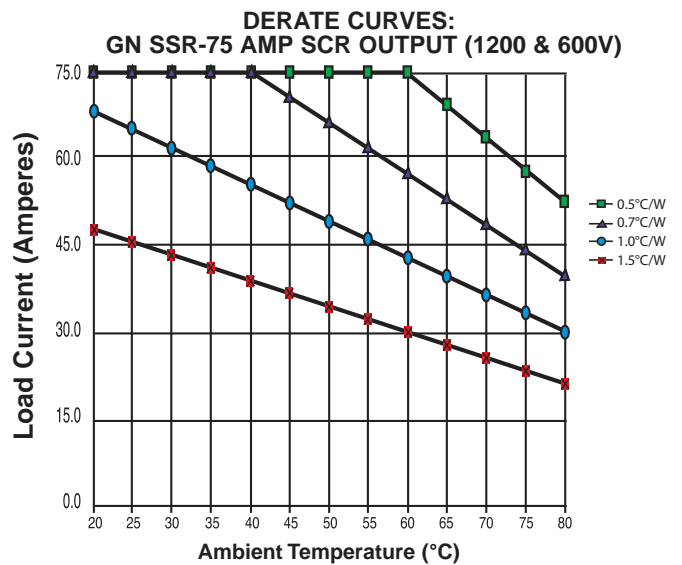
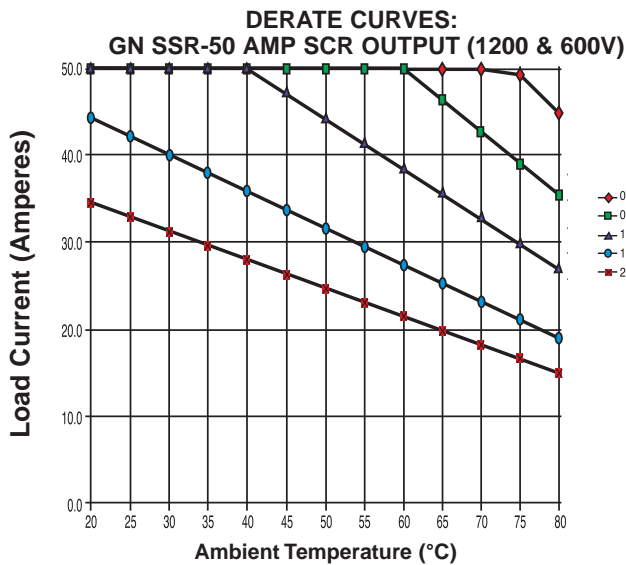
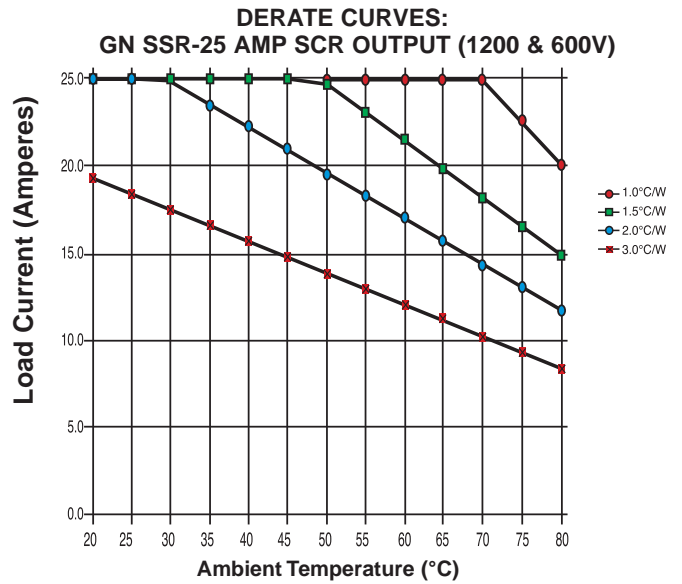
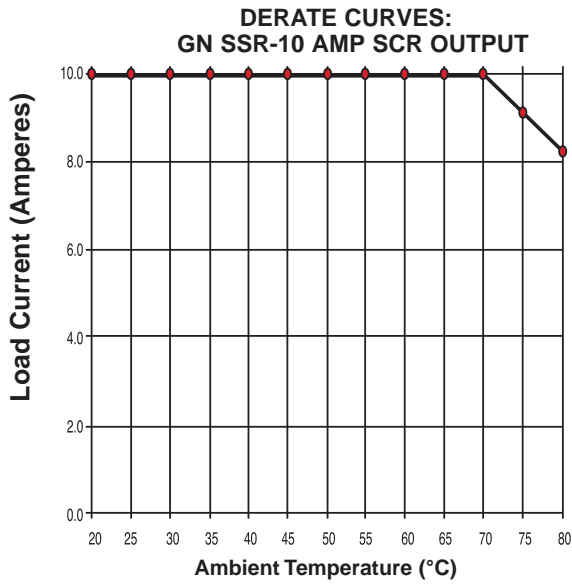

Products and specifications subject to change without notice.

Order/Technical Support – Tel: (877) 502-5500 / FAX: (619) 710-8540 / www.crouzet-usa.com